

Bemag Mountings



Bemag mountings are used primarily within the Construction Industry and can accommodate high dynamic forces. The oversized end metals allows for improve bonded interface between the rubber and metal to increase the fatigue life, particularly where continuous dynamic forces are applied in shear. Available with M12 threads on request.

Advantages:

- Extended Fatigue Life
- High Resilience
- Ideal for Continuous Dynamic Forces
- Cut-Outs on Metals to stop twisting

Applications:

- Vibratory Rollers
- Compactors
- Construction Equipment

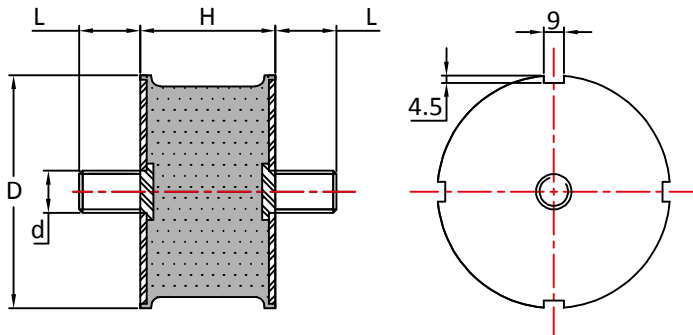

Male/Male

Part No	D	H	d x L	d x L
BM10540MM13/18	105	40	M16 x 13	M16 x 18
BM10540MM28	105	40	M16 x 28	M16 x 28
BM10555MM17/25	105	55	M16 x 17	M16 x 25
BM10555MM26/15	105	55	M16 x 26	M16 x 15
BM10555MM36/25	105	55	M16 x 36	M16 x 25

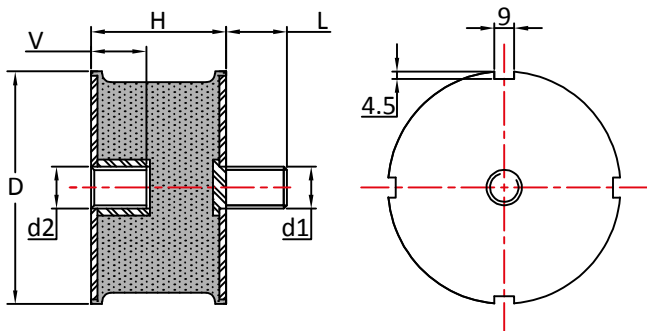

Male/Female

Part No	D	H	d1 x L	d2 x V
BM10540MF17	105	40	M16 x 17	M16 x 16
BM10555MF17	105	55	M16 x 17	M16 x 16

CONSTRUCTION, EARTH MOVING
AND AGRICULTURAL MACHINERY

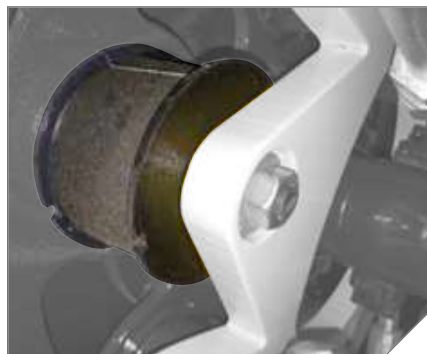

Max compression load in Kg deflection in mm.

This information is for guidance only. Customers are recommended to contact us for further technical information on products and applications. We reserve the right to alter specifications or withdraw products without notice.